

USER MANUAL



B140 / B140D

TABLE OF CONTENTS

- INTRODUCTION
- USER GUIDELINES
- PRODUCT FEATURES & ADVANTAGES
- PRODUCT COMPONENTS
- PART NAME OF CONTROL BOX
- BUTTONS ON THE OPERATION PANEL
- CONNECTION OF EACH PART
- OPERATION PROCESS
- MAINTENANCE OF THE PRODUCT
- PRODUCT SPECIFICATION
- WARRANTY
- SYMBOL

INTRODUCTION

Make sure to read this user manual before using. This user manual is to assure proper installation and use. Pay attention to read this manual in order to making the best use of this product and to assure the prolonged lifespan before using.

Specially, pay attention the contents with marks such as ,  and .

<Classification of equipment>

- Type of protection against electric shock
- Control Box: Class II appliance
- Handpiece: Class III construction
- Foot Controller: Class III construction

- Not suitable product in the atmosphere that exist flammable anesthetic mixture with air or with oxygen.
- Classification according to mode of operation: Intermittent operation

Design and specification of the product can be subject to be changed without notice for improving the quality.

USER GUIDELINES

WARNING

- Do not use as condition the collet chuck is opened. It causes product's malfunction.
- Do not open the collet chuck while the handpiece is operated.
- Check the power switch before connecting the power cord in order to decrease the danger by sudden operation of product.
- Connect the power cord after setting speed control dial at the '0' place (the end of counterclockwise).
- Circuit breaker is provided to protect the motor. It is actuated when an overload occurs which the motor cannot stand. Always use this product within allowable load range.
- Store the product as condition a bur is fixed at the collet chuck.
- Change the rotation direction after stopped the handpiece.
- Do not use the damaged bur. It causes product's malfunction and accident.
- Do not work in a dangerous place. Do not use the control box in a humid place.
- Do not disassemble or modify the product as one pleases. It causes accident.
- Use the compatible handpiece and foot controller with control box.
- Check the problems such as excessive vibration of bur, defective speed control and etc.
- Handle the speed control dial smoothly.
- Replace the bur after stopped the handpiece.
- Be careful not to drop the product as it may be damaged or broken. In case that it is dropped, check if the bur is bent or that any overheat is generated while carefully operating it.
- If any problem occurs in product, use after repairing.
- Do not put the handpiece down before it stops completely.
- Use the appropriate voltage for the product.
- Use the appropriate accessories for the product.
- Wear proper protective clothes and equipment, including a dust mask and safety goggles.
- Keep the workplace clean. Debris may cause an accident.
- Do not touch the power cord and handpiece cord with wet hand.
- Do not bend or press the power cord excessively. It causes fire or electric shock.
- Do not place the product nearby superheater, candle, lighter and etc. It causes fire.
- If use the extension cord, do not use many electric device at one time. It causes fire or electric shock.
- "This appliance can be used by children aged from 8 years and above and person with reduced physical, sensory or mental capabilities or lack of experience and knowledge if they have been given supervision or instruction concerning use of the appliance in safety way and understand the hazards involved."
- "Children shall not play with the appliance."
- "Cleaning and user maintenance shall not be made by children without supervision"
- "If the supply cord is damaged, it must be replaced by the manufacturer, its service agent or similarly qualified persons in order to avoid a hazard."
- Follow the user manual by manufacturer of bur to use bur.
- Keep the recommended speed limit by manufacturer of bur to use bur. If exceed the speed limit, it might cause an accident.

PRODUCT FEATURES & ADVANTAGES

- Hand/Foot Control Type
- Handpiece of DC Type 'STRONG 103L' Application
- Max. 45,000 rpm
- Max. 4 N-cm
- Rotation Direction Select Function (Forward/Reverse)
- Use the standard Bur Φ2.35mm
- Collet Chuck Type
- Overload Protection Function

PRODUCT COMPONENTS

* Please check all components are included.

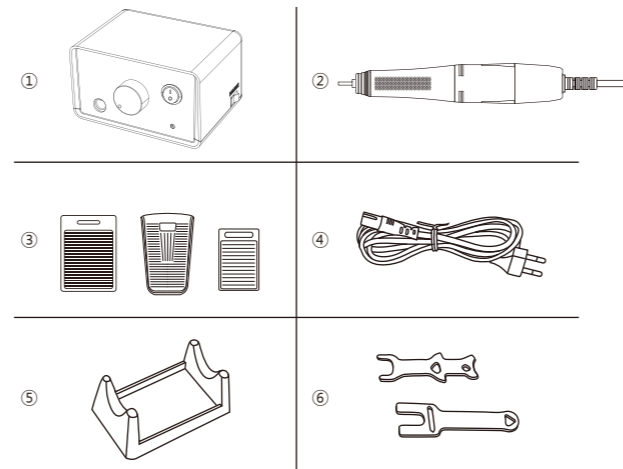

No.	Component
1	Control Box (B140 / B140D)
2	Handpiece (STRONG 103L)
3	3 Type Foot Controller (Option)
4	Power Cord
5	Handpiece Stand
6	2 Type Spanner

PART NAME OF CONTROL BOX

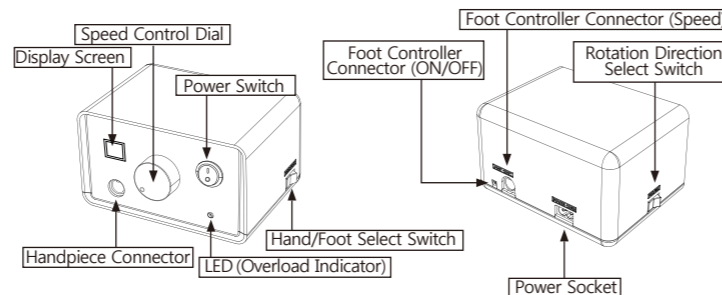

BUTTONS ON THE OPERATION PANEL

Power Switch:

This switch is used to turn on the power or off.
- I: Power On
- O: Power Off

Speed Control Dial:

This dial is used to control RPM. Turn the clockwise, RPM is increased. Turn the reverse, RPM is decreased.

Rotation Direction Select Switch:

This switch is used to select rotation direction to the clockwise or reverse.

Hand/Foot Select Switch:

This switch is used to select the handpiece operation method.
- Hand: Handpiece is operated by turning dial.
- Foot: Handpiece is operated by foot controller.

Display Screen (B140 Only)

- RPM: RPM is displayed. Display number x1,000 actual RPM.

CONNECTION OF EACH PART

Control Box Connection

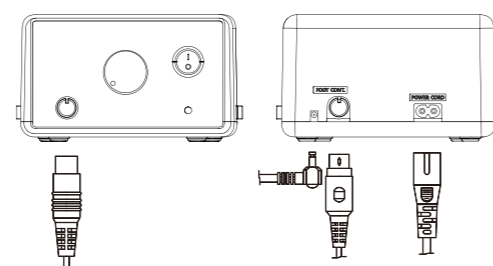

1. Connect the power cord to the power socket.

-  - Before connect the power cord, make sure to check the power off.
- Make sure to check that the speed control dial is set to '0'.

2. Connect the foot controller cord.

3. Connect the handpiece cord.

Bur Insertion

1. Turn the handle to open the handpiece chuck.

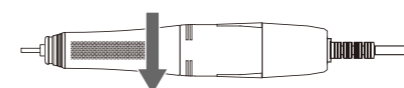

2. Insert the bur in the front of handpiece.

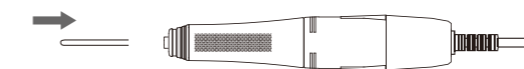

3. Lock the handpiece chuck by turning the handle.

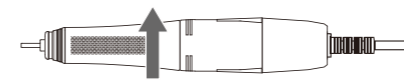

-  - Be sure to lock the chuck before use. It may cause damage to the handpiece.
- Make sure that the bur is not damaged.
- Check the Bur dimension. (Bur Dimension: Φ2.35mm)

OPERATION PROCESS

1. Put up the handpiece and turn on the control box.



2. Select the operation method by pressing the Hand/Foot Select Switch.

From the front of switch, the left is hand, the right is foot.

3. Select the rotation direction by pressing the Rotation Direction Select Switch.

From the front of switch, the left is forward direction, the right is reverse direction.

How to use when select the hand	How to use when select the foot
4. Control the desired speed by turning the speed control dial.	4. Control the desired speed by turning the speed control dial.
	5. Operate the handpiece by pushing the foot controller.
	• Speed Type – Control the speed within setting range.
	• ON/OFF Type – Speed is fixed with setting value.
	6. Foot controller is released, handpiece is stopped.

Overload Protective Function

If handpiece is overloaded, after about 5 seconds, LED (Overload Indicator) is turned on with beep sound and handpiece is stopped. For using handpiece again, turn it off and on.

MAINTENANCE OF THE PRODUCT

1. Keep the place around in handpiece clean from dust and grindings.
2. Remove dust on handpiece with alcohol and avoid humidity around.

-  - Do not apply the oil and water to the product.
- The grease inside of the bearing could melt away due to the oil.

3. Air cleaning is acceptable but air pressure may affect the handpiece or motor.
4. Store the product as condition a bur is fixed at the collet chuck.

PRODUCT SPECIFICATION

Control Box

Model Name	B140 / B140D
Input	AC 100-120 V, 50/60 Hz AC 220-240 V, 50/60 Hz
Fuse	AC 220-240 V, 2A
Power Consumption	16 W
Maximum Load Current	2 A

Handpiece

Model Name	STRONG 103L
Max. RPM	45,000 rpm
Torque	4.0 N-cm
Bur Replacement Type	Collet Chuck Type
Bur Dimension	Φ2.35 mm
Motor Type	DC Type

WARRANTY













SAESHIN guarantees out product for 1 year from invoice date, and product warranty means that SAESHIN has responsibility of defective material or operation failure. The product warranty does not cover user's misuse, wrong installation, inappropriate maintenance and repair, and normal wear of consumables such as bearings, spindle, gear, and motor. To check the warranty requires the operating condition, environment information, serial number of the product and stamped invoice. The warranty will be performed as repairs or exchanges by manufacturer's judgement and analysis of product.

Exception of warranty

- User's misuse or improper use and treatment
- Use the product with incorrect input voltage (AC voltage)
- Drop the device during setting, moving, using
- Use the not recommended consumables or accessories
- Malfunction after repairing the product at the not recommended repair shop
- Normal wear of the consumables such as ball bearing, gear, chuck, spindle case ass'y, motor
- Faulty by Act of God
- Attempt to disassemble or modify product.

Operating condition	Temperature (°C)	10~30
	Relative humidity (%)	10~80
	Atmospheric pressure (hPa)	700~1,060
Transport and Storage condition	Temperature (°C)	-20~60
	Relative humidity (%)	10~90
	Atmospheric pressure (hPa)	500~1,060

SYMBOL

	On (Power)		Off (Power)
	Manufacturer		Consult Instruction For Use
	EC Representative		General Warning Sign
	Serial Number		Class II appliance
	Fuse		Alternating Current
	This product should not be mixed with other commercial waste for disposal.		CE Marking



SAESHIN
SAESHIN PRECISION CO., LTD.
52, Sedheon-ro 1-gil, Dasa-eup,
Dalseong-gun, Daegu, Korea
Tel. 82-53-587-2341 / Fax. 82-53-580-0999
대구광역시 달성군 다사읍 세천로 1길 52
(성서모차산업단지)
Tel. 053-587-2345 / Fax. 053-580-0918
www.saeshin.com / traus@saeshin.com

MERIDIUS MEDICAL EUROPE LIMITED
Unit 3D, North Point House, North point
Business Park, New Mallow Road, CORK,
T23AT2P, Ireland
+353 212066448

SOM-L074S-KE [Rev.1] 2020-08-05